



## ED822-CW Specifications

Readability	0.01 g
Weighing capacity	820 g
Pan size	150 mm / 6 in.
Response time (avg.)	1.1 sec.
Dimensions - Overall:	(W x D x H): 230 x 303 x 87 mm 9 x 12 x 3.4 in.
Reproducibility	0.01 g
Linearity	0.02 g

### Standard Features:

White backlit, high contrast display with 15 mm digits

Built-in, motorized calibration weight: maximum weighing accuracy at a simple press of the respective key.

New operating concept: simple configuration of individual settings guided by short, menu-driven text prompts (choice of 5 languages) and by navigation using the cursor keys.

The most advanced microprocessor technology. More performance power for even faster and more stable readings

The level indicator is positioned in the direct vicinity of the display – this enables the user to quickly check whether the balance is correctly leveled.

Digital filter levels of the newest generation offer optimal prerequisites for adapting the balance to the conditions at the place of use.

Bidirectional RS-232C interface port, connection of the balance to a USB port by an optional Sartorius adapter cable.

ISO/GLP – compliant recording/printing of calibration, adjustment and weight values in conjunction with the optional YDP03-OCE data printer

Built-in application programs: calculation by a factor, weighing in %, net-total formulation; animal weighing; toggling up to 4 different units of measure, totalizing, count and density determination..

Total ease of operation. All keys feature positive click action. Clearly structured control panel



Data printer

Key accessories	Order no.
Data printer with date, time and statistics functions	YDP03-OCE
Data transfer software Software Wedge with RS-232C standard cable (1.5 m);	72US1010.3

Sartorius Corporation  
 131 Heartland Boulevard  
 Edgewood New York 11717  
 Toll Free: (800) 635-2906  
 ☎ (631) 254-4249  
 Fax (631) 254-4261

This Document Number:	
<b>Related Documents</b>	<b>#</b>
Applications Catalog	102000
Laboratory Catalog	1000
Calibration Catalog	80000

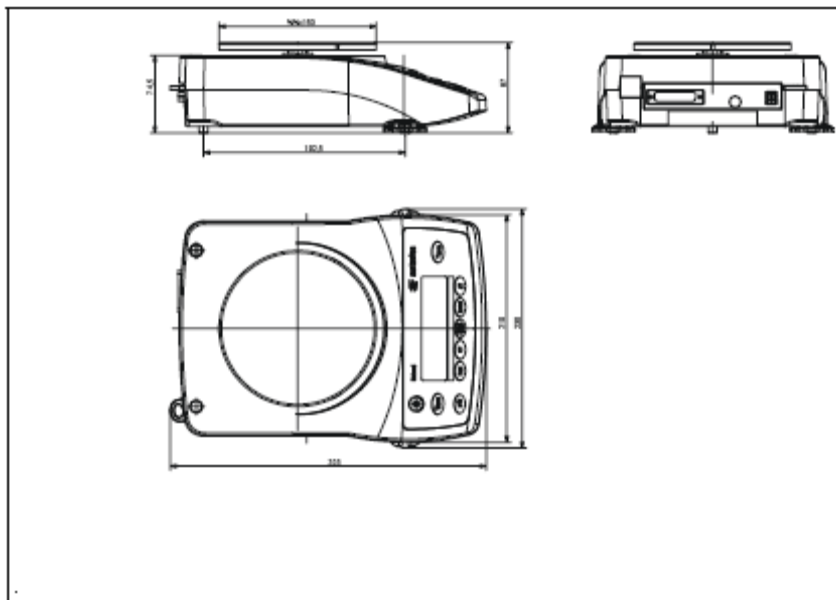

Alle Angaben in mm | All dimensions are in millimeters

Für Modell                      ED822, ED822-CW, ED822-OCE  
For Model

Sartorius Corporation  
131 Heartland Boulevard  
Edgewood New York 11717  
Toll Free: (800) 635-2906  
☎ (631) 254-4249  
Fax (631) 254-4261

This Document Number:		
<b>Related Documents</b>	<b>#</b>	
Applications Catalog	102000	
Laboratory Catalog	1000	
Calibration Catalog	80000	